

**Guidelines for “Thrust Sleeves Of Cast-In Resin Type“ with EPOCAST 36®**

**Designed for Wärtsilä-Sulzer Engines Type RT(A) to transmit the propeller thrust from the engine to the ship structure**

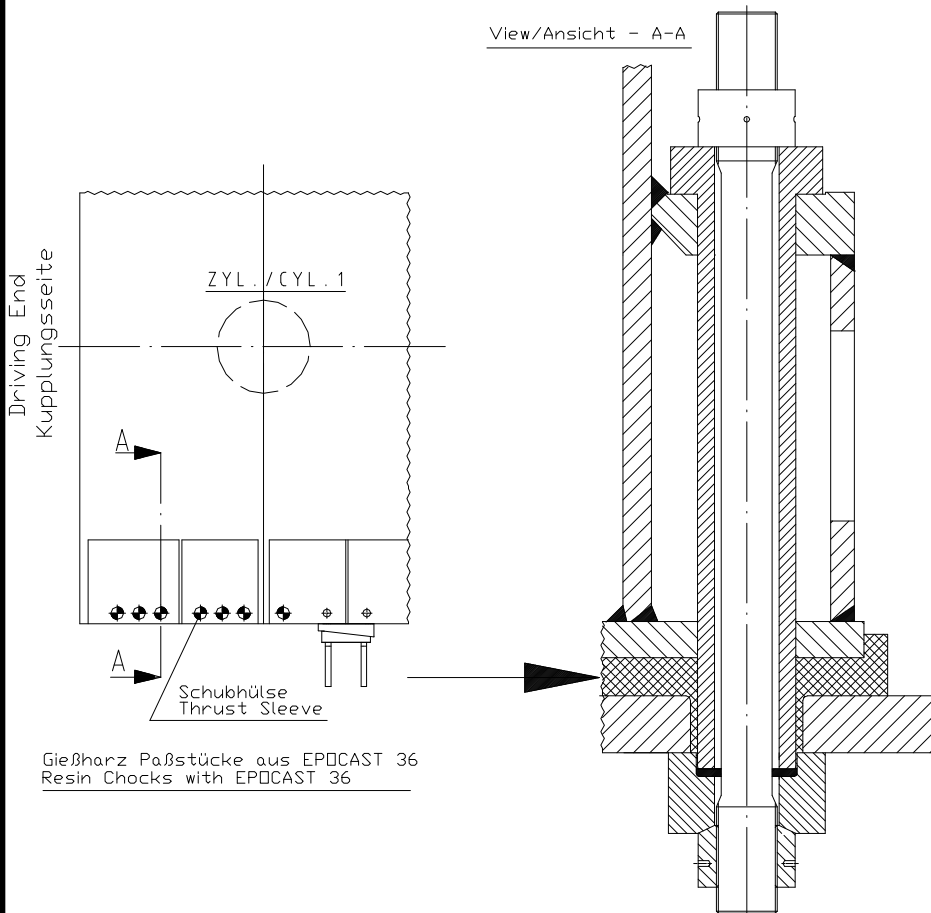

## 1.0 Introduction

The new technology to transmit the propeller thrust from the engine to the ship structure with Cast-In Thrust Sleeves is a new variant of chocking engines with epoxy resin. In the correct way applied this new technology saves time and money.

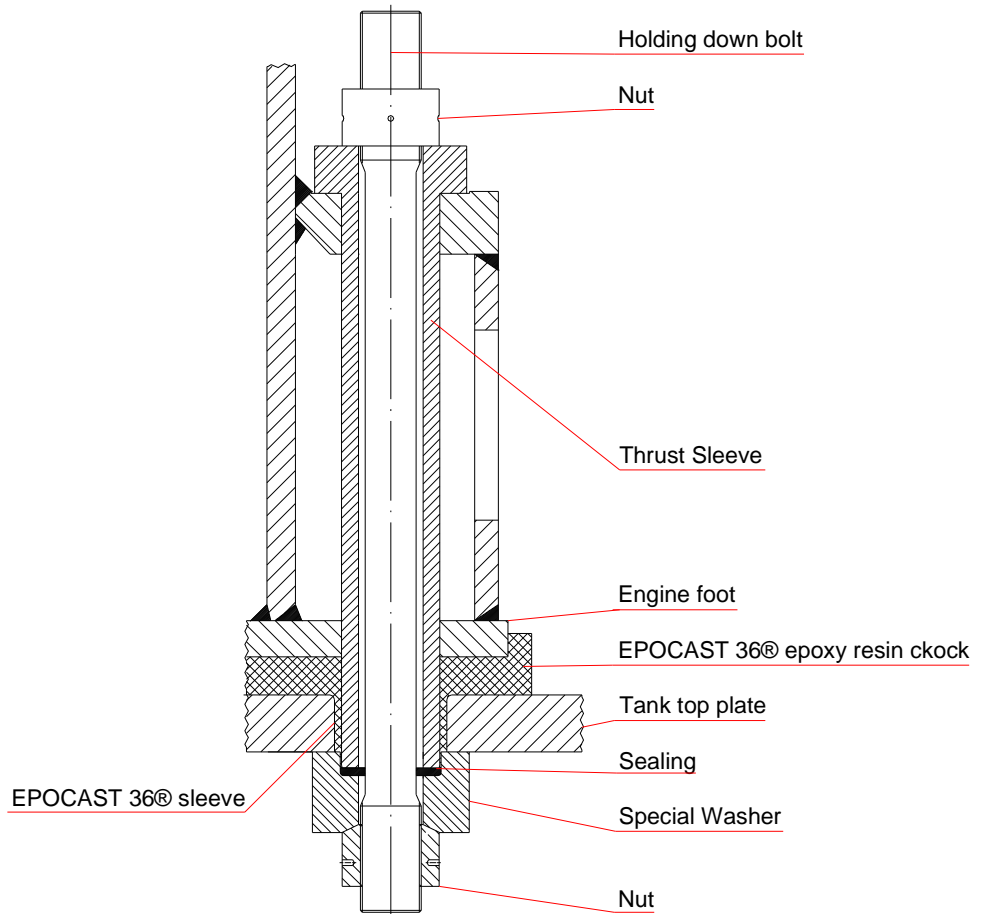

## 2.0 Preparation and procedure of pouring thrust sleeves with EPOCAST 36

### 2.1 General

Before chocking of the engine all damming work must be completed, thrust sleeves being fitted in position and holding down bolts being tightened by hand. Preheating of the **EPOCAST 36®** resin according to our Mixing and Pouring Guide 2.3.2 and preparation of the moulds according to our EPOCAST MARINE HANDBOOK Info 6-94-1-EP-E if not otherwise stated below.

### 2.2 Holes in tank top plate

The holes which are taking the thrust sleeves can be drilled or flame cut.

Hole diameter = Thrust sleeve diameter + 10 mm to max. 20 mm in average, which means the smallest distance between thrust sleeve and bearing surface (gap thickness) must not be less than 5 mm.

In every case holes must be free from burrs and flame cut holes must be metallic clean without notches.

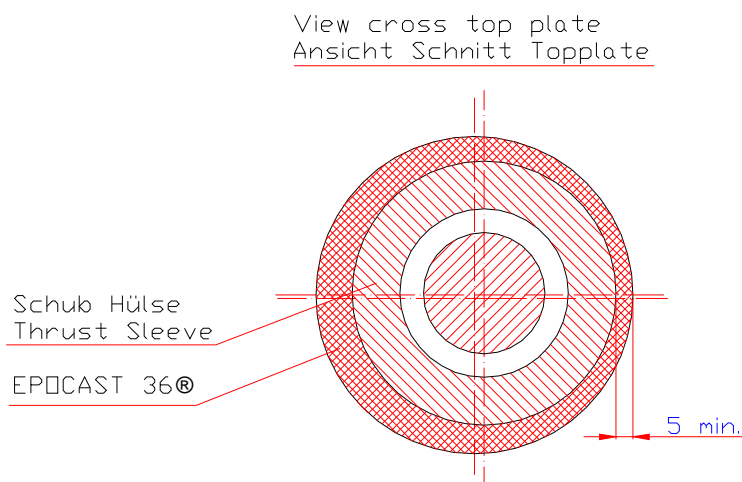

### 2.3 Face milling bottom side of tank top plate

- A) using of holding down bolts with special washers and nuts with spherical mating surfaces
- B) using of holding down bolts with special washers and nuts without spherical mating surfaces

To A: The bottom side of the tank top plate in the area of the holding down bolts must be plane when using special washers and nuts with spherical mating surfaces. A thin layer of Loctite, to seal the ring area of the washer to the tank top plate is acceptable.

To B: In case of using holding down bolts with special washers and nuts without spherical mating surfaces the contact area of the special washers to the tank top plate must be plane parallel face milled.

#### 2.4 Chock´s height in the area of thrust sleeves

The thrust sleeves and special washers supplied by Wärtsilä-Sulzer are manufactured in a way, that a chock height of min. 25 mm to max. 100 mm is covered. With correct installation of the thrust sleeves they should at least underlap 1 mm from the bottom side of the tank top plate.

#### 2.5 Thickness of sealing

The thickness of the sealing must be specified in a way to avoid any contact of the liquid **EPOCAST 36®** with the bolt thread.

#### 2.6 Pouring of chocks with thrust sleeves

Before pouring the chocks the integrated thrust sleeves must be sprayed with our Release Agent **FT 36**.

**ATTENTION: Smoke the total area only slightly with Release Agent!**

Preheating and mixing of **EPOCAST 36®** resin and hardener see "EPOCAST MARINE HANDBOOK / 2.3.2 MIXING UND POURING GUIDE".

The pouring of chocks with integrated thrust sleeve must be done in 2 steps:

- Step 1: Pouring of ring gap
- Step 2: Pouring of remaining chock

To step 1: Pour slowly mixed **EPOCAST 36®** resin and hardener into the ring gap so that the air can escape.

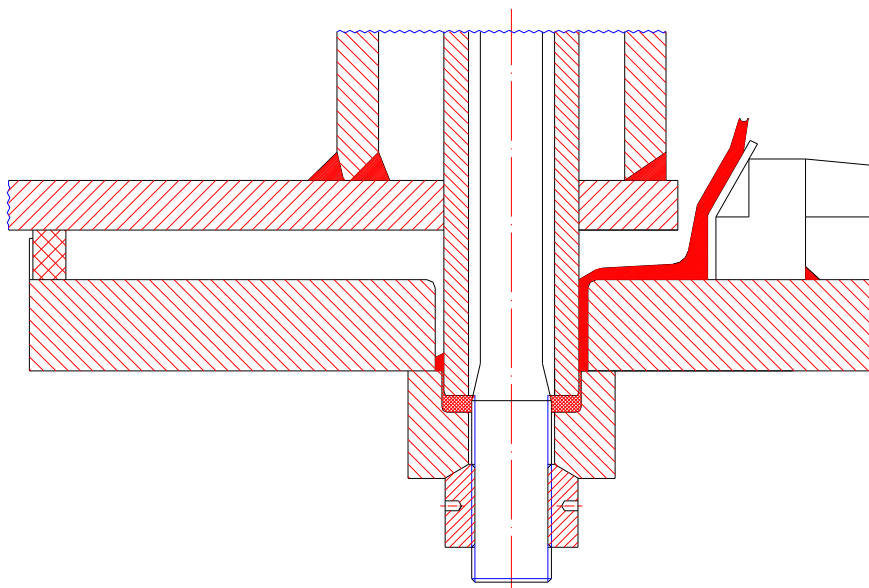

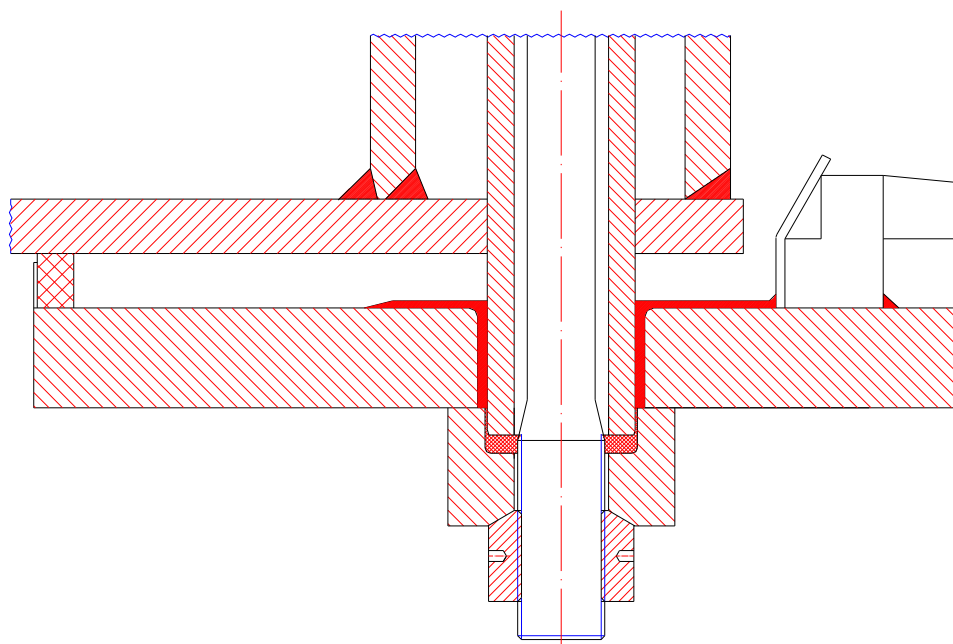

To step 2: After the ring gap is completely filled pour the remaining chock with **EPOCAST 36®** as usual.

